



*Fédération
Aéronautique
Internationale*

Minutes

of the
FAI Aerobatics Commission (CIVA)
Plenary Meeting

Held in Oberschleissheim, Germany
on Saturday, 5 November 2005 and Sunday, 6 November 2005

Version 1.2 / 21 November 2005

*Avenue Mon-Repos 24
CH-1005 Lausanne
(Switzerland)
Tél.: +41(0) 21/345.10.70
Fax: +41(0) 21/345.10.77
E-mail: sec@fai.org
Web: www.fai.org*

OFFICIAL MINUTES

FAI International Aerobatics Commission (CIVA) Meeting Held Oberschleissheim Germany 4-6 November 2005



IN THE CHAIR

President of CIVA	Michael R. Heuer
President of Honour	James M. K. Black
1st Vice President.....	John Gaillard (South Africa)
2nd Vice President.....	Jiří Koblíček (Czech Republic)
3rd Vice President	Osmo Jalovaara (Finland)
Vice President, Glider Aerobatics.....	Karl Berger (Austria)
Vice President - Finance	Lars-Göran Arvidsson (Sweden)
Secretary	Liz Cook (Australia)
.....	Carole Holyk (Canada)
FAI	Pierre Portmann, President of FAI
.....	Max Bishop, Secretary General
WGPA.....	Jean-Louis Monnet
Australia.....	Liz Cook, Delegate
Austria.....	Karl Berger, Delegate
.....	Dr Dietmar Poll, Observer
.....	Günter Meierhofer, Observer
Canada	Carole Holyk, Delegate
Czech Republic.....	Jiří Koblíček, Delegate
.....	Dr. Martin Vecko, Alternate
Denmark	Poul E.B. Nielsen, Delegate
.....	Karin Thomsen, Observer
Finland	Osmo Jalovaara, Delegate
.....	Matti Mecklin, Alternate
France.....	Robert Chomono, Delegate
.....	Madelyne Delcroix, Technical Specialist
Germany	Ernst Paukner, Delegate
.....	Manfred Echter, Alternate
.....	Jürgen Leukefeld, Observer
.....	Sylvia Leukefeld, Observer
.....	Hans Vogtmann, Technical Specialist
.....	Paula Paukner-Wagensohn, Observer
.....	Wolfgang Schweiker, Observer
.....	Bernhard Drummer, Observer
Italy	Maurizio Costa, Delegate
.....	Elena Costa, Observer
Lithuania	Algimantas Zentelis, Delegate
.....	Antanas Marciukaitis, Alternate
Norway.....	Tor André Fuldahl, Delegate
Poland.....	Jerzy Makula, Delegate
.....	Helmut Stas, Alternate
.....	Marek Szufa, Observer
.....	Stanislaw Szczepanowski, Observer
Russia	Elena Klimovich, Delegate
.....	Victor Smolin, Alternate
.....	Mikhail Mamistov, Technical Specialist
.....	Rolund Küng, Observer

Slovak Republic Pavol Kavka, Delegate
 South Africa John Gaillard, Delegate
 Spain Antonio Quintana Pereira, Delegate
 José Luis Olías Sánchez, Observer
 Flor Villar, Observer
 Manuel De Ugarte Rio, Observer
 Felipe Aresti, Observer
 Jose Luis Aresti, Observer
 Sweden Lars-Göran Arvidsson, Delegate
 Eva Reinmüller, Alternate
 Lars Frölander, Observer
 Joakim Grepe, Observer
 Switzerland Hanspeter Rohner, Delegate
 Beatrice Gugelmann, Alternate Delegate
 Philipp Sprecher, Observer
 Christine Rohner, Observer
 United Kingdom Alan C. Cassidy, Delegate
 Steve Green, Technical Specialist
 Dr. Derek Pike, Observer
 USA Debby Rihn-Harvey, Alternate
 Vicki Cruse, Observer
 Michael Steveson, Observer

OPENING REMARKS AND INTRODUCTIONS

President Michael Heuer opened the meeting at 09.05 on Saturday 4 November 2005.

President Heuer welcomed everyone to the 2005 CIVA Meeting and introduced Pierre Portmann President of FAI, Max Bishop Secretary General, James Black, President of Honour and the Officers of CIVA.

President Heuer thanked Hans Vogtmann for organizing the meeting.

A minute's silence was held in memory of Jean-Michel Delorme and Marta Meyer who had lost their lives since the WAC in Spain.

Proxies tabled:

- Ireland to Finland
- China to Sweden

President Heuer stated Mr. James Black would perform the role of Elections Officer. Ballot forms are to be returned to Mr. Black before 13.30 Saturday, 5 November.

1. MINUTES OF THE LAST MEETING 25-26 September 2004

No matters arising. No objections. Minutes Approved.

CIVA AGREED

2. DECLARATION OF CONFLICTS OF INTEREST

Mr. Alan Cassidy declared a possible conflict of interest as Chairman of the Catalogue Sub-Committee and publisher of the Aresti6 software.

3. FAI REPORT

President of FAI, Pierre Portmann

Mr. Portmann advised this is the first Commission meeting he has attended and it is useful to know the issues facing the Commissions. It is important that FAI is a modern, world sporting organization with a good management relationship between FAI and the Commissions.

Mr. Portmann stated the FAI WGP held at Lausanne was a success and gave a brief summary of the event.

Mr. Portmann referred to the work that has been completed by the Aresti Joint Committee. Members of the committee are Felipe Aresti, Jose Luis Aresti, Antonio Quintana and Osmo Jalovaara. Mr. Portmann congratulated Mr. Quintana and Mr. Jalovaara for their work.

Mr. Antonio Quintana introduced Felipe and Jose Aresti. Mr. Jose Luis Aresti addressed the meeting.

FAI Secretary General, Max Bishop spoke on the following:

- FAI Centenary Year
- Briefly discussed the work of previous Presidents and Secretary Generals
- FAI Book – "High Flyers" is available
- FAI Airshow at Lausanne – attendance 50,000
- FAI Membership – Active Members 76, Associate Members 12, Temporary Members 7, International Affiliates 2
- FAI income – 92% from membership fees. This is the reverse of other sporting organisations which are funded by the Olympic Federation.

- World Championships 2004 – 23 championships in 15 countries on 4 continents with 2339 competitors
- Over 70% of FAI championships are held in Europe with Germany the leader in participation. There is a need to boost the growth of championships in Asia and Africa.
- FAI Annual Questionnaire – 52 of 78 responses received. Main concerns over-regulations, airspace restrictions and sites.
- Compensation culture – insurance very costly. FAI taken steps to protect FAI representatives
- A need exists for paid consultants to assist countries in developing airports
- Flight safety – 249 fatalities which is a decrease however unacceptably high. CIVA has a very good record
- World Records and Notable Achievements were noted by the Secretary General for 2004
- FAI Staff – gives tremendous support.
- Max thanked Mady Delcroix for the work she has completed on early FAI records

Mike Heuer stated that it is a personal pleasure to work with such well-trained and supportive staff.

4. REPORT FROM THE PRESIDENT OF CIVA - Michael R. Heuer

Written report submitted. Report accepted.

President Heuer expanded on his report:

- 2005 Championships: A total of 131 pilots competed.
WAC: Sergey Rakhmanin (Russia) World Aerobatic Champion - 48 pilots competed.
WGAC: Georgi Kaminski (Russia) World Glider Aerobatic Champion - 38 pilots competed.
AEAC: Gerard Bichet (France) Advanced European Aerobatic Champion - 45 pilots competed.
- 65 FAI World and Continental Aerobatic Championships since 1960.
- 22 WPGA Events.
- Contest Organisation Handbook – work commenced and will be completed before 2006 season.
- Congratulations to Osmo Jalovaara, Matti Mecklin and the Aerobatic Club of Finland on receiving the FAI Group Diploma.
- Three Aerobatic Champions were honored at the FAI General Conference closing ceremony – Catherine Maunoury, Svetlana Kapanina and Jerzy Makula.
- Leon Biancotto Diploma – 2 nominations were received. Jiří Kobrle submitted by Aero Club of Czech Republic and Sándor Katona submitted by The Hungarian Aeronautical Association.

5. REPORTS ON THE 2005 WORLD AEROBATIC CHAMPIONSHIPS

- 5.1 President of the International Jury (Michael R Heuer).
Written report received. Report accepted.

Elena Klimovich raised 3 issues:

- a) Competition was stopped so 3 pilots could attend another competition.
- b) International Jury needs to ensure FAI and Organiser Medals are on site.
- c) Final Freestyle – Only top competitors show fly.

Mike Heuer replied:

- a) One pilot contacted Mike on behalf of all the Red Bull competitors several weeks before the championships. Members of the International Jury, Bureau and Chief Judge were contacted. It was a difficult decision to make and it was considered in the best interest of aerobatics to let these pilots attend the Red Bull event in Austria.
- b) Medals – will ensure the International Jury checks all medals. Mr. Manuel De Ugarte Rio advised Organiser Medals would be presented to the Delegates.
- c) Final Freestyle – Organisers requested pilots to fly.

Maurizio Costa stated:

- a) International Jury made the decision to allow pilots to fly with Red Bull without reference to the Teams.
- b) Final Freestyle – Only top pilots should fly.

Alan Cassidy stated:

- a) President's Report indicated judge's positions were satisfactory, however days were lost due to 90° judges position not being available. Organisers must have secondary position available. President's report to be amended.
- b) If Red Bull were affiliated with FAI it would be different position.

Comments were SO NOTED by the President and recorded in these Minutes.

- 5.2 Contest Director (Antonio Quintana)
Written report received. No discussion. Report accepted.
- 5.3 Chief Judge (John Gaillard)
Written report received. No discussion. Report accepted with discussion to be held later in the Agenda on the Chief Judge's recommendations for CIVA.

6. REPORTS ON THE 2005 WORLD GLIDER AEROBATIC CHAMPIONSHIPS

- 6.1 President of the International Jury (Karl Berger)
Written report received. No discussion. Report accepted.
- 6.2 Contest Director (Pavol Kavka)
Written report tabled at Plenary. No discussion.
- 6.3 Chief Judge (Helmut Stas)
Written report received. No discussion. Report accepted.

7. REPORTS ON THE 2005 ADVANCED EUROPEAN AEROBATIC CHAMPIONSHIPS

- 7.1 President of the International Jury (Osmo Jalovaara)
Written report received. Report accepted.
 - Osmo thanked Jiri Koblre for organizing the championships.
 - Elena Klimovich reminded Osmo that two judging positions were used not one.
 - President's Report to be amended.
- 7.2 Contest Director (Jiri Koblre)
Written report tabled at Plenary. No discussion. Report accepted.

Jiri advised only one Russian female pilot competed at the championships. Jiri suggested introducing a 'Women's' category in Advanced.
- 7.3 Chief Judge (Pavol Kavka)
Written report tabled at Plenary. No discussion.

8. RECOMMENDATIONS FOR RULE CHANGES FOR THE YEAR 2006

(Refer to CIVA web site for copies of the full submissions)

8.1.1 Report of the CIVA Rules & Judging Sub-Committee

Canada Proposal #1 Canada proposes that CIVA set up a working group, composed of specialists, that would submit their recommendations and comments to CIVA after analyzing all the Unlimited and Advanced 'Q' programme proposals submitted to CIVA. The final programmes for the next contest year will be decided by the CIVA Delegates at the Plenary meeting.

Tor André FUSDahl stated the working group must ensure Advanced difficulty does not 'creep up'.

It was proposed that the Bureau of CIVA be empowered to establish these Working Groups.

CIVA AGREED

Italy and Russia Proposal #1 - Order of Flight

Parts 1 and 3

1.1.7.2. For Programmes 1, 2 and 3 the competitors will be divided into 3 equal groups. The groups will be based on the provisional accumulated overall results after the previous programmes. The results of Programme Q will only be used with respect to Programme 1. The order of flight in each group will be determined by drawing of lots as described in paragraph 1.1.7.1. The flight order between groups is reversed to their rank. (The flights start with the group of the lowest rank). Nevertheless, for the last expected programme in case of time shortage, the flight can start with the top-ranking group. The lowest ranking group would fly only if the time left permits it.

CIVA AGREED

Italy and Russia Proposal #2 - Positioning K Factor

Reduce K factor for positioning to 30 in Unlimited and 20 in Advanced when there is no line judges.

Alan Cassidy spoke against the proposal – important component of the sequence.

Elena Klimovich – Without line judges the pilots can be disadvantaged – subjective call. K factor can be higher than most figures.

Vote: Favor of 9 Against 13

PROPOSAL FAILED

Italy and Russia Proposal #3 - K Factor Limit for Free Program in Unlimited

As there is no software restriction, the limit of 99 K for figures in the Unlimited Free Programme should be eliminated.

CIVA AGREED

Italy and Russia Proposal #4 - Hard and Soft Zeros

1. Change the conception of Hard and Soft zeros. Regard matters of fact as hard zeros and matters of perception as Soft ones. In this case it will be possible to view HZ on video.
2. A judge must mark a reason for HZ score on his / her score sheet. It will allow the Chief Judge to determine whether HZ stands even if one judge is right and eliminate judge's conferences in most cases.
3. HZ will be determined not by majority of judges but by establishing a fact.

CIVA AGREED

Italy and Russia Proposal #5 - Permitted Breaks

These rules changes would:

- Allow a pilot to make one unpenalized break in case of low clouds.
- Eliminate the necessity of an optional break to be marked on Form A, B, C.
- Change "regain height" to "readjust height" because a losing of height may be necessary for the second part of the sequence.

Parts 1 and 3, paragraph 1.4.2.6. - Permitted Breaks

- a) If during the performance of Programmes Q, 1, 2 or 3 the height of the cloud base is between the height of 1050 m and 800 m above aerodrome level, the International Jury may allow flights to be made in two parts, the competitor being allowed to readjust height without penalty to commence the second part.
- b) When an interruption occurs along the y axis, the competitor must resume his or her flight in the same direction of flight.
- c) If the cloud base subsequently rises to 1050 m pilots may no longer interrupt their flights without penalty; with due warning, i.e. at least 10 minutes in advance, pilots will be advised by the Contest Director (or his staff), following advice to him from the International Jury, when they are to fly without interruption.

Note: even though an interruption may be allowed without penalty by the International Jury, there is no obligation for pilots to interrupt their flight.

CIVA AGREED

Italy and Russia Proposal #6 - Minimum Time For A Pilot To Get Ready For A Flight

There should be not less than 15 minutes between the engine shut off and the next start up on the same airplane. The eligibility for a delay with start up must be confirmed by starter (problems with refueling, seat change and so on).

CIVA AGREED

Russia Proposal #8 - Drawing Of Lots To Submit Unknown Figures

Amended proposal – National Aero Clubs having 3 or more pilots to have priority. Reasoning is the same as in Advanced.

CIVA AGREED

Russia Proposal #9 - Flight Regulations and Local Flight Rules

English transcription of applicable Flight Rules published by the Aviation Authority of a country organizing international competitions, Local Regulations must be published by the organizer in a bulletin or on the event web-site.

CIVA AGREED

Russia Proposal #10 - YAK-52 Championships Free Programme

The Free Programme may be composed of a maximum of 12 figures or combinations of figures. A combination will be taken as one figure. All figures must be taken from the FAI Aerobatic 4 Catalogue as currently amended by CIVA. The total difficulty coefficient of all figures and combinations of figures shall not exceed 225.

Versatility:

In order to achieve versatility in the design of Programme 1, it is a mandatory requirement that competitors shall include the following. Programmes not including these figures will not be accepted:

- a) At least one figure from Family 2.3 to 2.20
- b) At least one figure from Family 5
- c) At least one figure from Family 7
- d) At least one figure from Family 8
- e) At least one figure each from Families 9.1. through 9.8
- f) At least two figure from Family 9.9
- g) Only one figure from Family 9.11 or 9.12
- e) At least one figure with opposite rolls

CIVA AGREED

b) Unknown Programme Refer original proposal.

Proposal was amended to exclude Family 2.6 to 2.15 for the initial competition. Position to be reviewed.

CIVA AGREED

c) Technical Inspection

Competing airplanes must pass the technical inspection of wing attachment units. They must have the g-load limit of +7/-5 and equipped with checked and sealed accelerometers. For exciding g-limit a pilot will be disqualified for the competitions.

CIVA AGREED

d) Height Limitations and Penalty Interruption

Upper Limit 1350m without interruption
Upper Limit 1050 with interruption
Lower limit 300m
Penalty for Interruption 50 points

CIVA AGREED

Sweden Proposal #3 – Electronic Tracking and Height Measuring Devices (amended)

In addition to the options of the electronic instruments in 2.1.4.1 CIVA should investigate the use of an electronic tracking device. Bureau of CIVA to be authorized to conduct the investigation and make decisions.

Alan Cassidy recommended amendment 'Bureau of CIVA be authorized to conduct the investigation and make *recommendations* to Plenary.

CIVA AGREED

Sweden Proposal #4 - International Judges visual acuity

It is proposed that all CIVA judges attending international and continental championships demonstrate visual acuity to the standard of a private pilots' licence.

Manfred Echter – proposal is not practical – how would it be administered. Look at JAR for private pilots licence.

Elena Klimovich – responsibility of Delegate

Proposed: That the Bureau of CIVA be authorized to consider visual acuity standard and make recommendation to Sub-Committee.

Vote Favor of 10 Against 11

PROPOSAL FAILED

United Kingdom Proposal #2 - 1.4.6.1.a) Interruption of Q Programme

Add new sentence to the end of the existing paragraph:

“In the event that a pilot takes a permitted weather break, the stop watch will be stopped on the third wing-dip at the start of the break and re-started on the third wing-dip signaling the beginning of the second part of the broken sequence.”

CIVA AGREED

United Kingdom Proposal #3 - Appendix 1, Family 5

Alan Cassidy withdrew proposal so as not to cause considerable work for Aresti Committee

United Kingdom Proposal #4 - Appendix 1, Family 7.31-7.38

Re-word as follows:

“Besides possessing the unique characteristic of containing three 45 degree lines on which rolls may potentially be placed, these sub-families should be judges as 7.32 to 7.30 but with the addition of an extra 45° line.

Radii of the entry/exit 1/8 loops and the two 3/4 loops must all be equal. The two 3/4 loops must have the same diameter and occur at the same altitude. The horizontal entry/exit heights must coincide with the top and bottom of the loops, except when the first or last 45° lines contain multiple linked, unlinked or opposite rolls, when they may be extended (not shortened) above or below the extreme of the 3/4 looping segments. Any rolls placed on any 45° line must be centred. (Figure 34)

CIVA AGREED

United Kingdom Proposal #5 - The Qualifying Programme (name clarification)

Withdrawn

United Kingdom Proposal #7 - Appendix 3, Family 5

Withdrawn

United Kingdom Proposal #8 - 1.2.3.1 Free Programme (Advanced)

The Free Programme may be composed of a maximum of 12 figures...

Vote: Favor of 10 Against 11

PROPOSAL FAILED

United Kingdom Proposal #9 - 1.2.3.6.f, Free Programme Versatility (Advanced)

Change "one" to "three" flick rolls required

Vote: Favor of 8 Against 12

PROPOSAL FAILED

United Kingdom Proposal #10 - Appendix 3, Family 5

Withdrawn

USA Proposal #1 Unknown figures

Amend Part 1 and Part 3, Appendix 3 to add the 9.1.3.1 (1/4 slow roll), 9.1.3.3 (3/4 slow roll), and 9.4.3.3 (3 of 4 hesitation roll).

CIVA AGREED

USA Proposal #2 Mandatory Line Judges

The USA proposes to make Line Judges mandatory at all World Championships with the following provisions:

Amend Section 6, section 2.1.11:

"If an electronic tracking device is not operated, line judges will be used. In this case, the use of line judges is mandatory at World Championships and may only be waived under special circumstances, by prior application to the Bureau of CIVA. Line judges should, if possible, be"

Amend Parts 1 & 3, section 2.1.4.2:

"If an electronic tracking device is not operated, infringements of the performance zone will be recorded by Line Judges. The use of line judges at World Championships may only be waived under special circumstances, by prior application to the Bureau of CIVA."

Amend Parts 1 & 3, section 2.2.3.1:

"...infringements may be recorded by a technical device or by four Line Judges. Contest organizers may decide to dispense with the recording of performance zone infringements in all but World Championship competition. The use of line judges at World Championships may only be waived under special circumstances, by prior application to the Bureau of CIVA. In any case, should recording of performance zone infringements be waived, the highest K factors will be used for positioning marks (see 2.1.4.5). The decision....."

Elena Klimovitch – Each line must be judged by 2 line judges. Prefer International Judges.

Maurizio Costa – aircraft now flying faster, more performance, additional G, harder to stay in the box. Comment Noted.

Vote: Favor of 10 Against 11

PROPOSAL FAILED

FAIR PLAY SYSTEM

Dr Derek Pike gave a comprehensive presentation on the proposed Fair Play System supported by Alan Cassidy and Steve Green.

Refer submitted report for details of the system.

Proposed that the FPS be adopted as submitted by Alan Cassidy and explained by Dr. Derek Pike. That a working group of 3 be established to finalise the remaining implementation details.. The group to include Alan Cassidy, Michel Dupont and Mikhail Mamistov. FPS to go into effect in 2006 season.

Vote: Favor of 20 Against Nil

CIVA AGREED

8.2 Report of the CIVA Glider Aerobatics Sub-Committee

Written report submitted. No objections

CIVA AGREED

Karl Berger advised that Marti Kalko has donated a new trophy for the winner of the Combined Unknowns at WGAC. Trophy to be known as 'Charles Kalko Trophy'.

CIVA AGREED

8.3 Report of the CIVA Catalogue Sub-Committee

Written report submitted. Refer 8.1 for amendments to Catalogue.

Osmo Jalovaara gave a brief update on the Catalogue.

- In May 2005 the control of the FAI Aerobatic Catalogue went to Aresti System SL
- FAI/Aresti Joint Committee has been formed to discuss problems.
- Aresti System SL controls publication and once the catalogue is confirmed to be available, it will be removed from the CIVA website.
- Minor changes will be free of charge and will issue very soon after Plenary Meeting.
- Agreement is in place that it must be published in a reasonable amount of time.
- Osmo thanked Antonio Quintana for work on the Committee.

Osmo also discussed the Aresti Trophy

- Trophy has suffered slightly from traveling around the world.
- Antonio Quintana will present a proposal for a substitute trophy.

President Heuer thanked Antonio Quintana for chairing the joint committee. He also thanked Jose Luis Olias and Manuel Ugarte for their assistance.

8.4 Reorganisation of Section 6 and CIVA Regulations

There were several questions in regard to perceived changes in the regulations. John Gaillard confirmed that he had not made any changes to regulations. After discussion it was agreed that these changes had been approved at previous Plenary Meetings. Document requires formatting and proof reading.

John Gaillard stated next exercise is to re-write Sporting Code to remove duplication.

Manfred Echter questioned whether the Gliders should consider amalgamating their documents.

Reorganisation of documentation to continue.

CIVA AGREED

8.5 Urgent Proposals from Championships

Proposals from Poland (WGAC 2005)

a) GENERAL: Rules Making Procedure (Trial Period of Amendments)

Each Amendment to the Rules should have temporal status for one calendar year. The change remains valid (permanent) after one year of test, if there is no objection to it. If the practice shows that amendment is not valuable, previous text of the Rules becomes obligatory again. After each year of experience CIVA considers the sense of introducing last amendments into the Rules as obligatory status.

Reason: It is easy to observe, that many (too many!) amendments introduced to the Rules each year (esp. for gliders) missed their required purpose.

Vote: Favor of 4 Against 15

PROPOSAL FAILED

c) Appendix No.1 CIVA Regulations – Part 2 Events for Gliders

Catalogue Families Family 9.9 and Family 9.10

Manfred Echter stated change is superseded by earlier decision on HZ/SZ.

Poland agreed. Proposal withdrawn

d) Proposal to cancel the hard/soft zero system and return to the old scoring system.

John Gaillard stated SZ's encourage judges to be more critical.

Vote: Favor of Nil Against 18

PROPOSAL FAILED

Proposals from Russia

Proposal #1 - That the International Jury check the availability of appropriate medals and diplomas at the beginning of the World and European Championships in accordance with the FAI Sporting Code and CIVA Regulations.

President Heuer stated that the requirement would be included in the Contest Organisation Handbook.

Proposal #2 - In case of a repeated Q program flight, pilot is allowed to re-fly only Q program and safety figures, not training if he had an opportunity to fly for 10 minutes the first time.

Vote: Favor of 7 Against 14

PROPOSAL FAILED

Proposal #3 That warm-up pilots shall not pay Entry Fee

Vote: Favor of 20 Against Nil

CIVA AGREED

Proposal from Finland – Permitted AWAC Aircraft

From the proposal:

When CIVA in its 2003 meeting adopted a new ruling regarding permitted AWAC aircraft, the Ultimate 10-300S was not included on the list, where it had been for several years.

This aircraft is a biplane built in 1988 with a 300 hp Lycoming and registered for the sake of less rigorous maintenance rules as "experimental" as all other aerobatic airplanes in Finland.

Currently its engine is limited by the governor for noise reduction reasons to maximum of 2500 rpm. This reduces the maximum power available by about 7% to 280 hp.

The spirit of the CIVA ruling requiring experimental aircraft with 6-cylinder engines to produce a current bench test was clearly meant to apply to new unknown aircraft designs entering the contests. Sending this engine to USA for a test bench run would cost an unreasonable amount of money, probably more than 10,000 euros.

Ultimate 10-300S has participated in two AWAC's and one AEAC. It is a known aircraft type with a good performance for Advanced category, but definitely not better than that of the high performance monoplanes like CAP 231, Extra 300 and the 360 hp Sukhoi currently permitted in Advanced. When CIVA expanded the number of permitted Advanced aircraft with the above mentioned ones not anymore sufficient for Unlimited category, it would be rather counterproductive to exclude this plane due to the changed rules that now prevents it from taking part in International competition without a bench test.

Alan Cassidy objected to ignoring a rule for one type of aircraft. Rule loses authority. Objection noted.

Vote: Favor of 19 Against Nil

CIVA AGREED

Proposal from USA

From the proposal:

At the last 2 World Championships (and possibly at others before), there have not been enough women's teams to have a team competition. The USA proposes that in the event there are not 3 or more teams of 3 or more men or women, that the number of pilots required to constitute a team be reduced to 2. At the WAC in Spain, this would have allowed for 4 women's teams (US, Russia, France, and Italy).

We propose a new rule be added and numbered 1.2.4.1.a.3 and to read as follows:

"In the event that fewer than 3 Teams comprised of 3 or more male or female pilots required to constitute a Team will be reduced to 2. The requirements in section 1.2.3.1 still apply."

CIVA AGREED

Proposals of the Chief Judge, WAC 2005

Proposal #1 - That CIVA continue to develop the JPI system, but until such time as the system is such perfected and considered to reflect accurately the performance of the judges, that the results not be published or issued to the judges themselves in order to avoid them modifying their behavior with the intention to improve such ratings.

That until such time that the JPI is perfected, the CIVA Bureau will select the panel of judges prior to the contest to a maximum of ten and a minimum of seven, thus eliminating the use of JPIs in the Q Programme where more than ten judges are present.

Elena Klimovich asked what criteria would be used. Recommended holding analysis from judges while program is running.

Pavol Kavka stated judge's performance will change with receipt of JPI.

Vote: Favor of Nil

PROPOSAL FAILED

Proposal #2
Withdrawn

Proposal #3 - That the regulation be changed to indicate that a 'Soft Zero' be given if no slide backwards is detected (tailslide judging criteria).

Vote: Favor of 20 Against 2

CIVA AGREED

Proposal #4 (Amended)

That the regulation be reworded to make it compulsory for the International Jury to change the flight order in order to avoid pilots flying the same aircraft being flown consecutively, the wording suggested is as follows:

"The sequence of flights may be altered by the International Jury, to ensure if possible at least two flights between competitors flying the same aircraft. The International Jury should ensure in this process that competitors remain within the same grouping when a random draw has taken place. No discussion will be entered into concerning this process."

CIVA AGREED

Proposal #5 That an additional paragraph be added under the Sporting Code – Air Safety, to read as follows:

"Any competitor required to break-off a competition flight danger due of collision with unauthorised air traffic or a bird strike, would be treated in the same manner as if a mechanical defect had taken place with regards to a re-flight as applicable. If a required to orbit to avoid any such hazard the Chief Judge will allow additional time if required."

CIVA AGREED

Proposals from President of the International Jury, AEAC 2005
(refer proposals for full details)

Proposal #1 - Because neutrality is absolutely essential for a judge, based on this study, I propose this check be included in the Fair Play System and also as a component in the JPI calculation.

CIVA AGREED

Proposal #2 - That CIVA should consider the shortening of the Unknown compulsory preparation time from 24 hours to 18 hours between publication and commencement of program.

CIVA AGREED

9. CIVA KNOWN COMPULSORY PROGRAMMES - 2006

Glider Known Programme - Recommended by Glider Sub-Committee

GASC proposal adopted.

Unlimited Q

	First Vote	Second Vote
Australian proposal	Favor of 1	
UK proposal	Favor of 2	

Finnish proposal	Favor of 4	Favor of 6
French proposal	Favor of 7	Favor of 14
Russian proposal	Favor of 3	
USA proposal	Favor of 1	

French proposal adopted.

Advanced Q

	First Vote	Second Vote	Third Vote
Australian proposal	Favor of 4	Favor of 7	Favor of 8
UK proposal	Favor of 3		
Finnish proposal	Favor of 4	Favor of 6	
French proposal	Favor of 6	Favor of 9	Favor of 13
Russian proposal	Favor of 3		
USA proposal	Favor of Nil		

French proposal adopted.

Yak 52

Russian proposal	Favor of 12
South African proposal	Favor of 7

Russian proposal adopted.

Known/Q Programmes for 2006 are attached to these Minutes.

10. FUTURE AEROBATIC CHAMPIONSHIPS - REPORTS AND PROPOSALS

10.1 2006 Advanced World Aerobatic Championships

- a) Proposal of Poland - Marek Szufa referred to the presentation document which was given to all Delegates on a disk.
 - Site: Radom (central Poland)
 - Dates: 3-13 August 2006
 - Entry Fees: Pilots €1350; Team Members €1150
 - Entry Fees (excluding accommodation/meals): Pilots €550; Team Members €250
 - Aircraft for hire from Radom Aeroklub: 3 Extra 300L, 2 Zlin 50LS
 - Hangarage available
 - Accommodation: Hotels 1k and 15k from airport
 - Box over airfield
 - Training camps to be organized

- b) Report from USA – Michael Steveson
 - Site: Jean, Nevada, USA
 - Dates: 5-14 October 2006
 - Entry Fees:
 - Pilot Double - US\$1700 Early registration; US\$1900 Late registration
 - Pilot Single - US\$2000 Early registration; US\$2200 Late registration
 - Team Member Double - US\$1600 Early registration; US\$1800 Late registration
 - Team Member Single US\$1600 Early registration US\$1800 Late registration
 - Aircraft for hire: numerous Extra, Yak, SU-29, Zlin 50, and others. A dedicated contact will be available to assist with arrangements.
 - Hangarage: temporary tent structure 65x200 feet
 - Box adjacent to airfield
 - Accommodation – 2 hotels on site

Vote: Favor of Poland 14
Favor of USA 7

The submission of Poland was accepted.

CIVA AGREED

The FAI Organiser Agreement was signed by FAI Secretary General Max Bishop, Polish CIVA Delegate Jerzy Makula and CIVA President Mike Heuer.

10.2 2006 European Aerobatic Championships (Report from Switzerland)

Philipp Sprecher, Contest Director referred to presentation document and overheads:

- Site: Grenchen
- Dates: 29 August-10 September 2006
- Entry fee excluding accommodation/meals (lunch at airfield included):
Pilots €1100; Team Members €700
- Hangarage not available
- Box adjacent to runway
- Accommodation – organizer will assist through competition website

Russia and Italy stated the entry fee was high as it does not include accommodation and meals. Philipp stated that it will cost SF50,000 to hold the event and they are still looking for sponsors.

Norway asked if it is possible to train in Switzerland. Philipp advised not possible.

President Heuer remaindered the Delegates that the bid of Switzerland had already been approved. The discussion is only relative to entry fee.

The proposed entry fee as submitted by Switzerland was rejected by CIVA.

Vote: Favor of 3 Against 9

Hanspeter referred the matter back to Switzerland for discussion and then returned with a proposal for a reduced Entry fee of €1000 for Pilots and €600 for others.

Vote: Favor of 15 Against 2

CIVA AGREED

The FAI Organiser Agreement was signed by FAI Secretary General Max Bishop, Swiss CIVA Delegate Hanspeter Rohner and CIVA President Mike Heuer.

10.3 2006 European Advanced Aerobatic Championships (Report from Poland)

Jerzy Makula referred to presentation document, which was given to all Delegates on a disk:

- VIII European Glider Aerobatic Championships will be held at Rybnik, Poland
- Dates: 19-29 July 2006
- Entry Fees: €550 pilot; €250 Observer
- Towing fees: 1200m €55; 800m €48
- Free hangar storage available
- Invited all to attend Polish National Championships one week before EGAC.

No objections to entry fees

CIVA AGREED

The FAI Organiser Agreement was signed by FAI Secretary General Max Bishop, Polish CIVA Delegate Jerzy Makula and CIVA President Mike Heuer.

10.4 2006 Yak 52 World Aerobatic Championship

John Gaillard referred to presentation document:

- Site: Hluhluwe, South Africa
- Dates: 8-17 June 2006
- Entry fees: €1300 Pilots; €1200 Team Members and Observers
Single supplement €200
- Full support of local Municipal Manager
- CIVA Regulations for competition already covered
- SA National Championships previously held at site
- No weather problems
- No malaria problems
- Contest Director: John Gaillard
- Invited all to attend the SA Nationals the week before the YAK-52 competition
- Proposed 3 Jury Members and 5-7 Judges
- Bulletin 1 will advise cost of aircraft rental

Elena Klimovich stated the proposal to reduce the number of judges was rejected last year – must have at least 7 judges.

John Gaillard proposed That CIVA allow a minimum of 5 maximum of 7 judges. Jury to be 3 including the Chairman.

Favor of 18 Against 2

CIVA AGREED

There was no discussion or objection to the entry fees

CIVA AGREED

The FAI Organiser Agreement was signed by FAI Secretary General Max Bishop, South African CIVA Delegate John Gaillard and CIVA President Mike Heuer.

10.5 2007 World Aerobatic Champion ships – No proposals received.

10.6 2007 Advanced European Aerobatic Championships (Proposals Invited)

Osmo Jalovaara advised:

- Site Joensuu Finland
- Date – July 2007
- 3 airfield available for training
- Full details to be provided at next CIVA Meeting.

CIVA AGREED to Finland holding the 2007 AEAC

10.7 2007 World Gilder Aerobatic Championships (Proposal from Austria)

Karl Berger advised:

- The Austrian Aero Club wishes to organize the event
- Site: Niederöblarn, Austria
- Dates: August 2007
- Entry fees to be advised at CIVA 2006

Mr. Sepp Schlager, President of the Australian Aero Club referred to previous events held in Austria and thanked Delegates for the opportunity to organize this event.

CIVA AGREED to Austria organizing the 2007 World Glider Aerobatic Championships

11. WORLD GRAND PRIX - John Gaillard First Vice President of CIVA

Jean-Louis Monnet advised:

- WGPA is now a different format
- Organisers seek participants
- Qualification day for pilots
- Not all dependent on CIVA
- Judges are chosen through CIVA
- 2006 Events:
 - January Al Ain,
 - Motegi must advise this month
 - South Korea – October
 - Malaysia – December.

John Gaillard asked if the Organiser is FAI approved.

Max Bishop stated that if pilots are not suitably qualified they cannot fly in an FAI event. To be further discussed outside this meeting.

Max Bishop also stated:

- Must protect the rights to our events
- Transfer rights have a financial value
- Don't underestimate value of rights
- International events belong to CIVA
- Every pilot must have an FAI Sporting Licence
- Red Bull are engineering their success at our expense
- Take difficult decision and withdraw pilot's licence if flying in non-FAI sanctioned events.
- Preferable to hold joint agreement.

President Heuer stated that it was agreed at the 1995 Plenary "If any of our pilots competes in a non-FAI event then we have the right to rescind their FAI Licence." Mike also noted that all pilot profiles included in Red Bull documentation refer to FAI medals and championships.

12. LIST OF INTERNATIONAL JUDGES

Refer to updated list on CIVA web site.

13. ANY OTHER BUSINESS

13.1. Budget 2006 (LG Arvidsson)

LG stated:

- 2005 net loss of approximately US\$42,000
- Main costs
 - Fair Play System US\$17,000
 - Payment to Aresti US\$10,000. Future payments: 2006 and 2007 US\$10,000 each year
 - Championship stipends US\$26,000
- WAC Burgos had the best judging line ever. CIVA must be an independent organization which requires sound financial base.
- Proposed double entry fees and cancel all stipends for 2006
- Only way to achieve a positive result in 2006 is to raise the sanction fees

- Sanction fees is only income
- If sanction fees are raised then it may be possible to pay stipends
- If holding a championship submit budget to CIVA

Pavol Kavka questioned cost of Fair Play System.

LG raised the subject of the FAI fund. Submit proposal for cost of Fair Play System.

Max Bishop confirmed FAI would accept proposals for the development of aerobatics. Max also asked the question as to why CIVA had 5 persons on the International Jury when all other Commissions have 3.

Elena Klimovich stated a paper should have been submitted to the Delegates and the issue discussed at the informal meeting.

Mady Delcroix stated that it was unfair to ask Switzerland to lower the entry fee and then increase the sanction fee.

LG stated income from WPGA in 2005 would be US\$4,000 for AI Ain.

Pavol Kavka questioned the number of judges. LG stated reducing the number of judges reduces organizer costs.

President Heuer proposed that the sanction fees be doubled.

Vote: Favor of 14 Against 6

CIVA AGREED

President Heuer proposed that the Jury be reduced to 3 including the Chairman and Judges to minimum 5 and maximum of 7.

Elena Klimovich raised the matter of correct procedures regarding proposals for CIVA. President Heuer stated Elena is correct regarding our rules process but these proposals are a result of the financial report. The Bureau had worked on the financial report up until the last moment.

Alan Cassidy suggested separating the proposal into two (Jury and Judges).

Proposals were modified.

That the judges consist of a maximum of 7, minimum of 5

Vote: Favor of 14 Against 4

CIVA AGREED

That the Jury be reduced to 3 (Chairman and 2 members for all championships)

Vote: Favor of 19 Against Nil

CIVA AGREED

President Heuer will review election results and advise composition of Juries.

Alan Cassidy stated that stipends are not paid at Continental Championships. Matter should be re-considered for Continentals.

LG stated that he had considered all proposals as a Contest Organiser.

Manfred Echter stated cost of development of Fair Play System is very high.

Alan Cassidy stated a further small payment for meeting work to be paid.

President Heuer apologized to CIVA for the late information and stated these matters will be discussed at informal sessions in the future and the reports provided sooner.

Vice-President – Finance report and financials to be accepted.

CIVA AGREED

13.2 President's Proposals (Michael R. Heuer) - None

13.3 Contest Scoring Program Report (Michel Dupont)
Written report submitted.

Mike Heuer advised Michel is working on the implementation of FPS into ACMS and it will be ready for the 2006 season.

13.4 Leon Biancotto Diploma for 2005

Nominations received:

Jiří Koblí – Aero Club of Czech Republic
Sándor Katona – Hungarian Aeronautical Association

Jiří Koblí strongly recommended support for Sándor and said he was an exceptional man. Mady Delcroix responded saying that Sándor would also fully support Jiří in the same manner.

There were no objections to awarding the Leon Biancotto Diploma in 2005.

CIVA AGREED

Vote: Jiří Koblí 12 votes Sándor Katona 7 votes

13.5 Proposed New European Mixed Team Trophy

Italy proposed a new trophy – The Franco Battistoni Trophy
Full details to be submitted to CIVA
There were no objections to this new trophy.

CIVA AGREED

13.6 Glider Advanced Championship

Manfred Echter advised there was an interest in holding an Advanced Glider Championship
Full details to be submitted to CIVA.

13.7 FAI Sporting Licence

Alan Cassidy raised the issue of revoking pilots FAI Sporting Licences if they fly in non-sanctioned events. Max Bishop requested a show of hands to indicated support for this initiative. A clear majority of Delegates indicated support.

It was agreed that the Bureau of CIVA be allowed to investigate with FAI and take the matter forward.

CIVA AGREED

14. ELECTIONS

Position	Nominee	Votes
President	Michael Heuer (USA)	Elected unopposed
First Vice President	John Gaillard (RSA)	Elected unopposed
Second Vice President	Jiri Koblre (CZE) Alan Cassidy (GBR)	18 4
<u>Mr. Koblre elected Second Vice President.</u>		
Third Vice President	Osmo Jalovaara (FIN)	Elected unopposed
Vice President, Gliders	Karl Berger (AUT)	Elected unopposed
<u>Mr. Berger elected Vice President – Gliders Aerobatics</u>		
Secretary	Liz Cook (AUS)	
Secretary	Carole Holyk (CAN)	
Rules Sub-Committee Chairman	Jiri Koblre (CZE)	Elected unopposed
Rules Sub-Committee Members		1 st Vote
	Liz Cook (AUS)	16
	Alan Cassidy (GBR)	18
	Robert Chomono	18
	Lars Frolander (SWE)	16
	Vladimir Popov (RUS)	8
	Eugenjius Raubickas (LIT)	4
	Brian Howard	17
<u>Those elected are Cassidy, Chomono, Howard, Frolander and Cook</u>		
Judging Sub-Committee Chairman	John Gaillard (RSA)	Elected unopposed
Judging Sub-Committee Members		
	Greg Dungan (USA)	12
	Robert Chomono (FRA)	10 (Withdrew)
	Helmut Stas (POL)	7
	Vytautas Tautkevicius (LIT)	3
	Osmo Jalovaara (FIN)	15
	Bela Guraly (HUN)	3
	Mikhail Mamistov (RUS)	11
	Stephen Green (GBR)	10
	L-G Arvidsson (SWE)	16
<u>Those elected are Arvidsson ,Jalovaara, Mamistov, Dungan and Green.</u>		
Catalogue Sub-Committee Chairman	Alan Cassidy (GBR)	Elected unopposed
Catalogue Sub-Committee Members		
	Brian Howard (USA)	17
	Madelyne Delcroix (FRA)	15
	Manfred Echter (GER)	12

Jerzy Makula (POL)	12
Carole Holyk (CAN)	15
Anatoly Belov (RUS)	10

Those elected are Howard, Delcroix, Echter, Makula and Holyk

Glider Aerobatics Sub-Committee

Marti Kalko (USA)
 Madelyne Delcroix (FRA)
 Manfred Echter (GER)
 Helmut Stas (POL)
 Ludwig Fuss (GER)
 Carlo Marchetti (ITA)
 Bela Guraly (HUN)
 Jerzy Makula (POL)
 Pekka Havbrandt (SWE)
 Premysel Vavra (CZE)
 Karl Berger (AUT)
 Beatrice Gugelmann (SUI)
 Sergei Krikalev (RUS)
 Gregori Kaminsky (RUS)
 Matti Mecklin (FIN)

All those nominated received at least 7 votes and are elected as there is no limit on the size of the Glider Sub-Committee.

Working Groups

Contest Organisation Group:

Mike Heuer, Chairman (USA); John Gaillard (South Africa); Karl Berger (Austria) Jürgen Leukefeld (Germany), Lars-Göran Arvidsson (Sweden), Max Ungricht (Switzerland), Steve Green (Great Britain), Graham Hill (Great Britain)

Strategic Planning Group:

John Gaillard, Chairman (South Africa); Manfred Echter (Germany), Dominique Roland (France), Osmo Jalovaara (Finland), LG Arvidsson (Sweden), Liz Cook (Australia), Don Peterson (USA), Mikhail Mamistov (Russia)

FAI World Grand Prix of Aerobatics:

John Gaillard, Chairman (South Africa); John-Louis Monnet (Switzerland), Graham Hill (Great Britain), Greg Dungan (USA)

Fair Play System:

Alan Cassidy (United Kingdom), Mikhail Mamistov (Russia), Michel Dupont (France).

Q Programme Analysis (Advanced)

To be named

Q Programme Analysis (Unlimited)

To be named

15. APPOINTMENT OF OFFICIALS (International Jury and Chief Judges)

15.1 2006 Advanced World Aerobatic Championships

President of the International Jury

Mike Heuer (USA)

21

Elected Unopposed

Members, International Jury

Ernst Paukner (GER)	4
Jiri Koblre (CZE)	14
Robert Chomono (FRA)	11
Pavol Kavka (SVK)	1
LG Arvidsson (SWE)	14
Elena Klimovich (RUS)	6
Carole Holyk (CAN)	6
Osmo Jalovaara (FIN)	9
Liz Cook (AUS)	12

Those elected are Koblre, and Arvidsson (1st Reserve – Chomono, 2nd Reserve Jalovaara)

Chief Judge

		Second Vote
John Gaillard (RSA)	9	10
Pavol Kavka	9	12

Mr. Kavka was elected Chief Judge

15.2 2006 European Aerobatic Championships - Switzerland

President, International Jury

Jiri Koblre (CZE)	7
Mike Heuer (USA)	14

Mr. Heuer was elected President.

Members, International Jury

Osmo Jalovaara (FIN)	16
L-G Arvidsson (SWE)	Withdrew
Ernst Paukner (GER)	4
Robert Chomono (FRA)	14
Lars Frölander (SWE)	10
Sergei Krikalev (RUS)	8
Jiri Koblre (CZE)	9
Carole Holyk (CAN)	7

Those elected are Jalovaara and Chomono (1st Reserve – Frölander, 2nd Reserve Koblre)

Chief Judge

Graham Hill (GBR)	11
Pavol Kavka (SVK)	9

Mr. Hill was elected Chief Judge

15.3 2006 European Glider Aerobatic Championships - Poland

President, International Jury

Karl Berger (AUT) Elected unopposed

Members, International Jury

	1 st Vote
Carlo Marchetti (ITA)	17
Bela Guraly (HUN)	16
Madelyne Delcroix (FRA)	18

Marti Kalko (USA) 18

Those elected are Delcroix and Kalko (1st Reserve – Marchetti, 2nd Reserve - Guraly)

Chief Judge

Helmut Stas (POL)	Elected unopposed
Pavol Kavka (SVK)	Withdrew
John Gaillard (RSA)	Withdrew

15.4 2006 YAK 52 World Aerobatic Championships – South Africa

President, International Jury

LG Arvidsson (SWE))	Withdrew
Liz Cook (Aus)_	Elected Unopposed

Members, International Jury 1st Vote

Alan Cassidy (GBR)	15
L-G Arvidsson (SWE)	Withdrew
Ernst Paukner (GER)	7
Liz Cook (AUS)	Withdrew
Lars Frölander (SWE)	12
Victor Smolin (RUS)	10
Jiri Kobrle (CZE)	15
Carole Holyk (CAN)	4
Algimantas Zentelis (LIT)	2
Valentina Drokina (RUS)	3

Those elected are Cassidy and Kobrle (1st Reserve - Frölander, 2nd Reserve - Smolin)

Chief Judge

Graham Hill (GBR)	Elected Unopposed
John Gaillard (RSA)	Withdrew

16. DATE AND PLACE OF NEXT MEETING

Krakow, Poland; 3-5 November 2006

Italy indicated they would submit a proposal to hold the 2007 Plenary Meeting.

President Heuer thanked Hans Vogtmann for organizing the meeting and presented him the FAI flag and FAI “High Flyers” book.

The meeting closed at approximately 13.00 Sunday, 6 November 2005

Submitted by Liz Cook
Secretary of CIVA
19 November 2005

Approved by Michael R. Heuer
President of CIVA
21 November 2005

Attachments:

#1 - Programme Q's and Knowns for 2006



2006		FORM B
Pilot ID #	Glider Known	
		Flight #

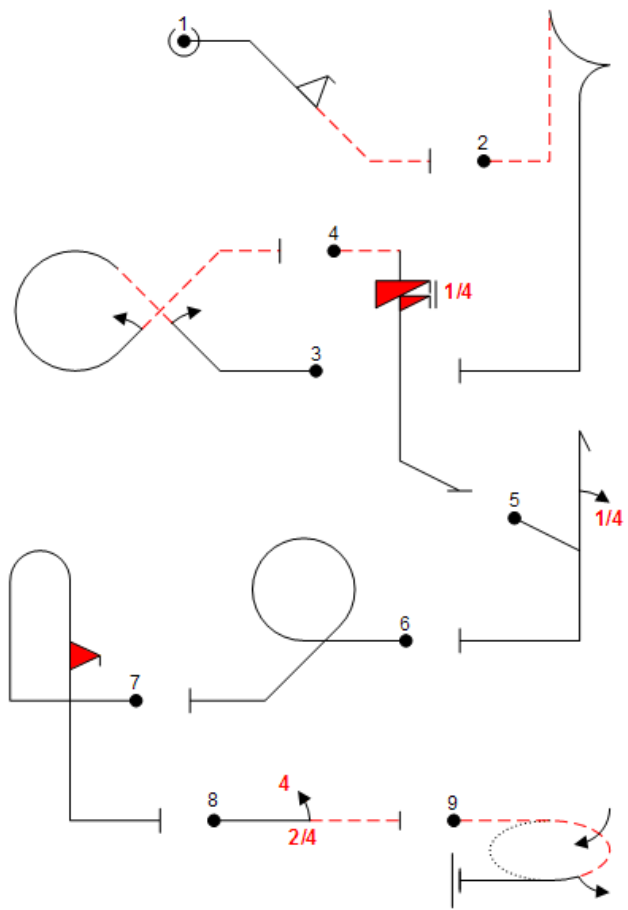
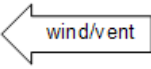

Fig 1	1.3.3 9.9.4.2	8 12	20
Fig 2	8.1.4	17	17
Fig 3	7.22.1 9.1.2.2 9.1.2.2	18 9 9	34
Fig 4	1.7.4 9.12.1.5	9 8	17
Fig 5	5.1.1 9.1.1.1	17 9	26
Fig 6	8.45.1	11	11
Fig 7	8.1.1 9.10.10.2	13 15	28
Fig 8	1.1.3 9.4.3.2	2 8	10
Fig 9	2.19.2	28	28
Total K = 191			

Created Using AesIG™ software. AC.Crestky@aol.com

 Pilot
 AC



2006		FORM B
Pilot ID #	Advanced Programme Q	
		Flight #

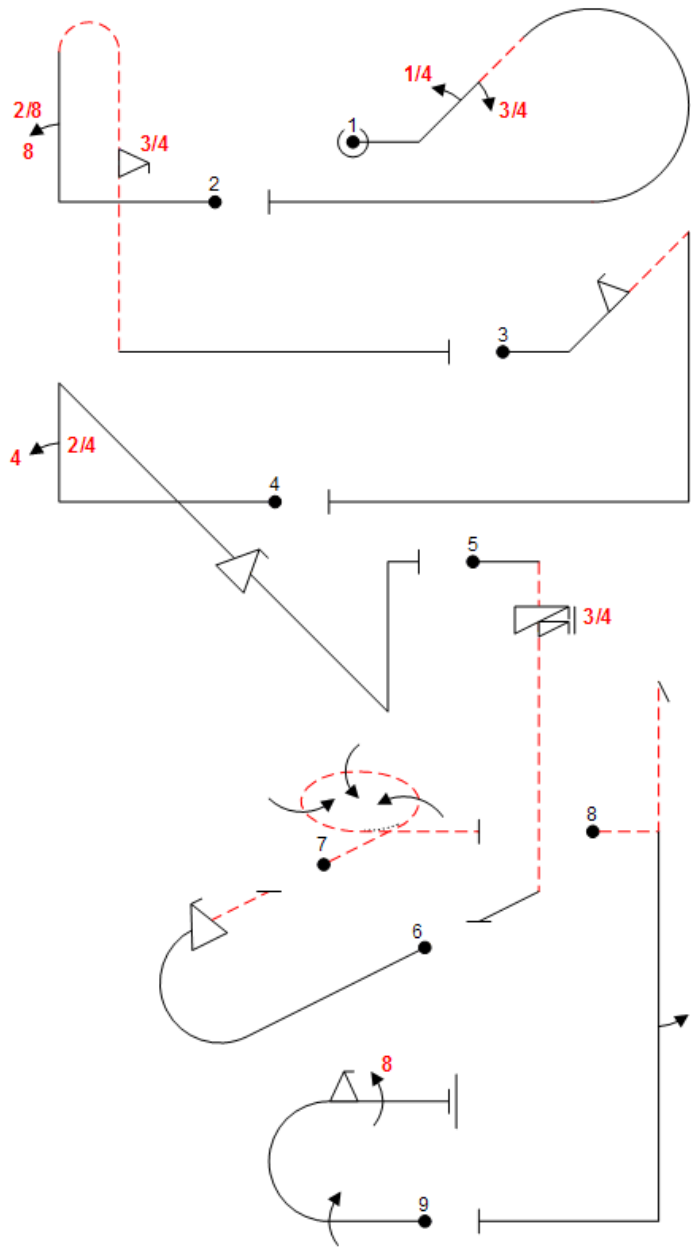
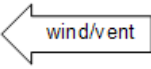
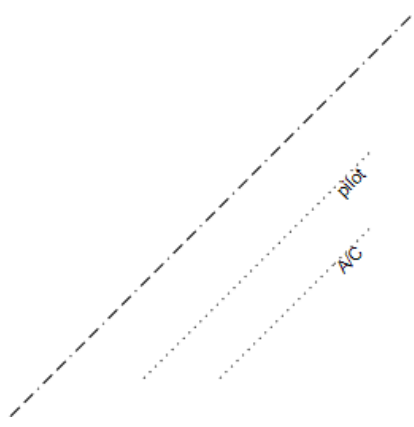

Fig 1	8.32.1 9.12.1 9.12.3	10 4 8	22
Fig 2	8.3.1 9.8.1.1 9.9.10.3	15 7 13	35
Fig 3	1.14.1 9.9.2.2	12 13	25
Fig 4	1.40.1 9.4.1.2 9.9.4.4	22 9 11	42
Fig 5	1.8.3 9.11.1.7	10 3	13
Fig 6	7.1.1 9.9.3.4	6 11	17
Fig 7	2.8.2	18	18
Fig 8	5.1.4 9.1.5.2	22 4	26
Fig 9	7.2.1 9.1.3.4 9.9.3.2 9.8.3.4	6 8 11 15	40
Total K = 238			

Created Using Aes10™ software. AC.Crestky@aol.com





2006		FORM B
Pilot ID #	Unlimited Programme Q	
	Flight #	

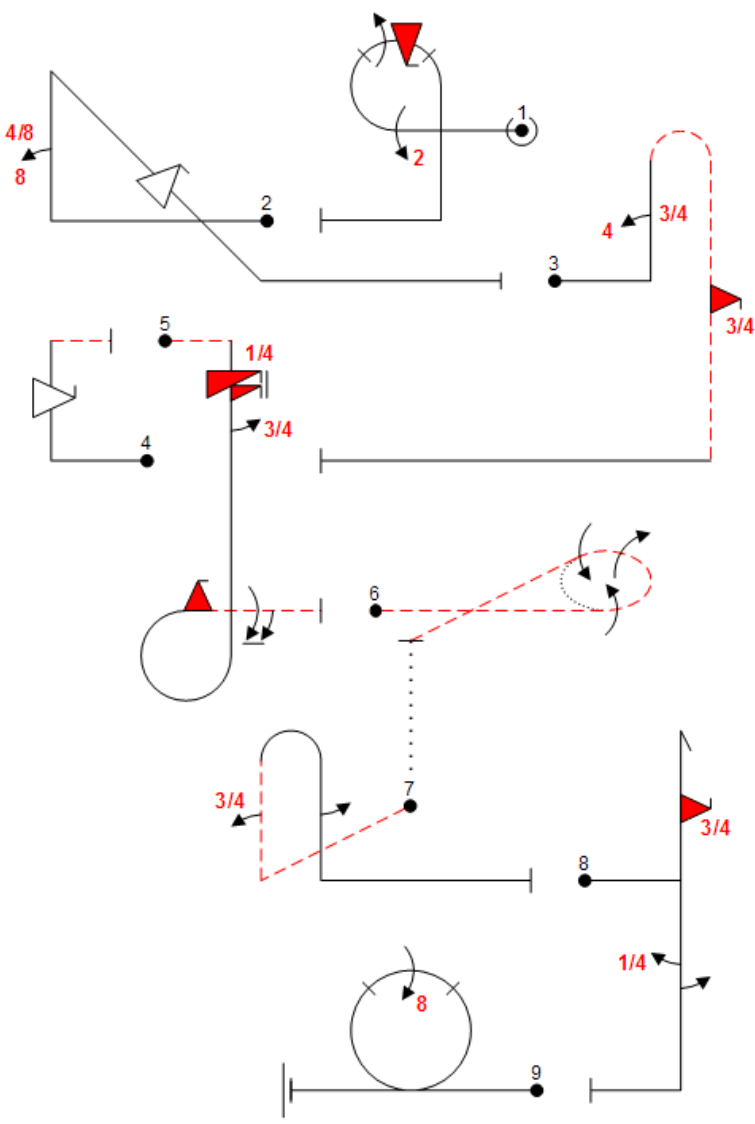
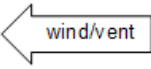
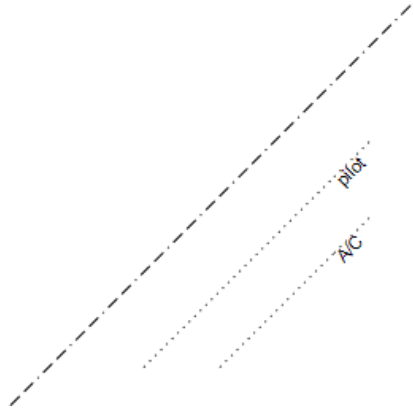

Fig 1	8.43.1	11	43
	9.23.4	9	
	9.13.4	8	
	9.10.8.4	15	
Fig 2	1.17.1	14	36
	9.8.1.2	11	
	9.9.4.4	11	
Fig 3	8.3.1	15	40
	9.4.1.3	12	
	9.10.5.3	13	
Fig 4	1.7.1	9	24
	9.9.1.4	15	
Fig 5	8.33.4	12	49
	9.12.1.5	6	
	9.15.3	6	
	9.10.8.2	15	
	9.13.6	10	
Fig 6	2.13.2	22	22
Fig 7	8.4.2	14	28
	9.1.1.3	10	
	9.15.2	4	
Fig 8	5.1.1	17	42
	9.10.6.3	19	
	9.15.1	2	
	9.15.2	4	
Fig 9	7.5.1	10	25
	9.8.3.4	15	
Total K = 309			

Created Using Aes10™ software. AC.Crestky@aol.com





Yak-52 World Championships		2006	FORM B
Pilot ID #	Programme Q		Flight #

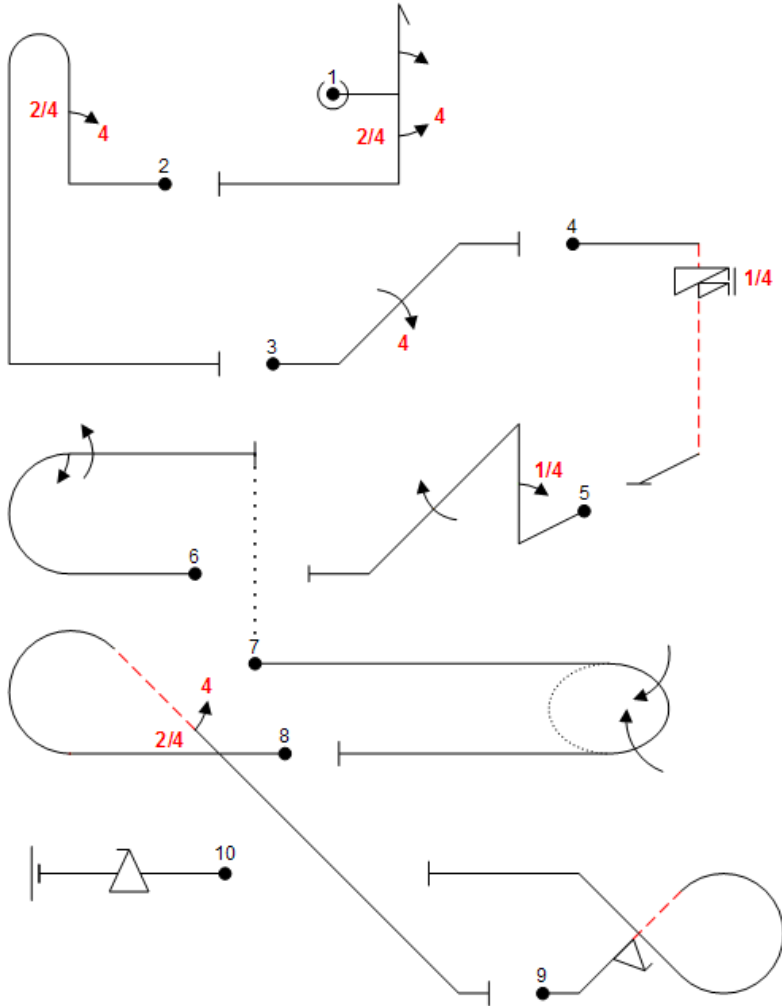
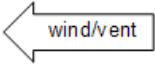

Fig 1	5.1.1 9.1.1.2 9.4.5.2	17 8 5	30
Fig 2	8.1.1 9.4.1.2	13 9	22
Fig 3	1.2.1 9.4.2.4	7 13	20
Fig 4	1.8.3 9.11.1.5	10 4	14
Fig 5	1.17.1 9.1.1.1 9.1.4.4	14 6 8	28
Fig 6	7.2.1 9.1.3.2 9.1.3.4	6 4 8	18
Fig 7	2.8.1	13	13
Fig 8	8.4.2.1 9.4.4.2	10 5	15
Fig 9	7.20.1 9.9.2.2	14 13	27
Fig 10	1.1.1 9.9.3.4	2 11	13
Total K = 200			

Created Using Aes10™ software. AC.Crestky@aol.com

