



# **26th FAI WORLD GLIDER AEROBATIC CHAMPIONSHIP**

# **14<sup>th</sup> FAI WORLD ADVANCED GLIDER AEROBATIC CHAMPIONSHIP**

## **Bulletin N°1**

**Oschatz 2024**

**GERMANY**



*Note: All participants are treated equally. For the sake of simplicity, gender-specific terms do not use both forms. Therefore, the chosen designation does not imply gender.*

## Content

Content .....	2
1. Scope and Purpose of the World Gliding Aerobatic Championships .....	3
2. Organizer and Host .....	3
3. Place and Dates .....	3
4. Contest Management / Organization .....	4
5. Contest Office / General Information .....	5
6. Language, Sports- and Operating Regulations .....	5
7. Team Composition .....	6
8. Entries and Registrations .....	7
9. Glider Aircraft .....	8
10. Free Known (Known) Sequence Submission .....	9
11. Entry Fees .....	9
12. Cancellation Curve & Refund Policy .....	10
13. Other Fees .....	11
14. HMD Device .....	11
15. Written Correspondence .....	12
16. Liability and legal action .....	13
17. Cancellation of the event .....	13



## 1. Scope and Purpose of the World Gliding Aerobatic Championships

### 1.1. Scope

The World Gliding Aerobatic Championships are held in two classes:

- „Unlimited“ - 26<sup>th</sup> World Gliding Aerobatic Championship
- „Advanced“ - 14<sup>th</sup> World Advanced Gliding Aerobatic Championship

A maximum of 6 programs will be flown in each class:

- Free Known (Known) Program 1
- 1. Unknown Program 2
- Free Unknown (Free) Program 3
- 2. Unknown Program 4
- 3. Unknown Program 5
- 4. Unknown Program 6

### 1.2. Purpose

- Determination of the Overall World Champion in each class.
- Determination of the Overall World Champion Team in each class.
- Determination of all other Winners.

## 2. Organizer and Host

Organizer: Deutscher Aeroclub e.V. (DAeC)  
Represented by Lars Czernek

Host: Fliegerclub Oschatz e.V.  
Represented by Roland Marsch

## 3. Place and Dates

### 3.1. Venue

Oschatz Airfield EDOQ  
Wermsdorfer Straße 36  
04758 Oschatz (Saxony)  
Germany

### 3.2. Dates

Unofficial Training Days	All day	22 <sup>nd</sup> – 26 <sup>th</sup> July 2024
Official Training Days	All day	27 <sup>th</sup> – 31 <sup>st</sup> July 2024
Official Day of Arrival	Wednesday	31 <sup>st</sup> July 2024
Opening Ceremony	Wednesday	31 <sup>st</sup> July 2024
Opening Briefing	Thursday	1 <sup>st</sup> August 2024
1 <sup>st</sup> Competition Day	Thursday	1 <sup>st</sup> August 2024
Last Competition Day	Friday	9 <sup>th</sup> August 2024
Reserve Day	Saturday	10 <sup>th</sup> August 2024
Closing Ceremony	Saturday	10 <sup>th</sup> August 2024

## 4. Contest Management / Organization

### Local Officials

Contest Director:	Thomas VON LARCHER
Deputy Contest Director:	Roland MARSCH
Office Manager:	Stephanie KOECHEL
Flight Director:	Heiko ECHKHARDT / Juergen SCHWIBS
Safety Officer:	Erik SIMON

### International Jury

President:	Vladimir MACHULA
Members:	Madelyne DELCROIX Pekka HAVBRANDT

### Board of Judges

Chief Judge:	Philippe KUECHLER
Judges:	will be announced later
Scoring Director:	Stefan WEISS

### Technical Committee

President:	Michael KAISER
Members:	Jan PAEPKE, Jan KRUMBHOLZ



## 5. Contest Office / General Information

- 5.1. The official working hours of the Contest Office and Organizers are from 08:00 CEST to 30 minutes after the landing of the last competitor or 18:00 CEST, whichever is later.
- 5.2. These hours are applicable for any official inquiries, information requests, or the submission of claims/protests related to the contest throughout its duration.
- 5.3. If not explicitly written, all times herein are stated in local time (CEST).
- 5.4. The schedule may be changed due to weather, technical or organizational reasons.

## 6. Language, Sports- and Operating Regulations

- 6.1. The official language for communications and briefings during all herein mentioned competitions is English.
- 6.2. All legal provisions and regulations concerning aviation that pertain to the championship in descending order of priority:
  - Standardized European Rules of the Air (SERA)
  - National Gliding Operations Regulations (S.B.O.)
  - National Civil Aviation Authority Regulations (LBA)
  - Local regulations applicable to this competition
  - FAI Sporting Code – General Section
  - FAI Sporting Code Section 6 – Part 2
- 6.3. The competition will be conducted based on the currently valid “Regulations for the Conduct of International Aerobatic Events” published by the FAI with all its appendices (as of 2023) and the FAI Sporting Code, General Section and Sporting Code, Section 6, Part 2, Gliding Aerobatics in the latest version, unless otherwise stipulated in this announcement and its addenda or the following implementation regulations.
- 6.4. Furthermore, the following are binding:
  - This Bulletin of the organizer with all supplements and all following bulletin revisions.
  - Specifications of the competition management at the opening briefing and at the daily briefings during the competition.
  - Local regulations issued by the organizer, if necessary, at the latest at the beginning of the official training days.

- 6.5. The current anti-doping regulations of the FAI, which are binding for all federal commissions, and thus the national anti-doping code apply. In particular, Article 9 of the Code states: An anti-doping rule violation in Individual Sports in connection with an In-Competition test automatically leads to Disqualification of the result obtained in that Competition with all resulting Consequences, including forfeiture of any medals, points and prizes.
- 6.6. The responsibility of all participating pilots to comply with the anti-doping rules remains unaffected by this information.

## 7. Team Composition

### 7.1. Competitors

- 7.1.1. Entries will be accepted according to FAI Sporting Code, Section 6 Part 2, 1.2.6 and herein listed item 8.
- 7.1.2. All FAI member National Aero Clubs (NACs) may be represented at the competitions by a team and/or individual competitor or observer.
- 7.1.3. All FAI member National Aero Clubs (NACs) may be represented at the competitions by a team and/or an individual competitor or observer.
- 7.1.4. Each NAC can enter up to a maximum of eight (8) competitors.
- 7.1.5. Each competitor shall have:
- A valid Glider Pilot License with an aerobatic extension according to competitor's national legislation. Launch Type "Aerotow" shall be included and valid.
  - A valid FAI Sporting License
  - A valid Medical Certificate
  - A valid Liability Insurance Policy
- 7.1.6. A competitor can only be entered for one class/championship.
- 7.1.7. For competitors who have not yet reached the age of 18 by the time of signature, the registration form shall also be signed by the legal representative.
- 7.1.8. If there would be over 70 competitors, the organizer reserves the right to decrease the number of competitors per team. NACs will be notified of at least two months prior to beginning of the event according to FAI Sporting Code, Section 6 Part 2, 1.2.6.1 a).



7.1.9. Participants are advised to have travel/health insurance valid in Germany at the time of the championship and training.

7.1.10. Violation of flight safety as well as other regulations will be resolved according to FAI Sporting Code Section 6, Part 2, 1.2.8.

## 7.2. Other Team Members

7.2.1. Each team may include the following officials:

- 1 Chief delegate
- 1 Team manager
- 1 Trainer / Coach
- 1 Interpreter
- 1 Doctor
- Up to 3 Mechanics

## 7.3. Observers

7.3.1. Other persons (i.e. team member's relatives) will be accepted as observers of National Team.

7.3.2. No Entry Fee for observers will be collected, but attendance at Opening and Closing Ceremonies/Dinners or other events of championships official program needs to be paid separately. This option will be available at info centre during championships.

## 8. Entries and Registrations

8.1. Deadline for the Entries and Registration is Wednesday, **30<sup>th</sup> April 2024 23:59h CEST.**

8.2. Registration forms shall be sent to [mail@wgac2024.de](mailto:mail@wgac2024.de) or via [Online Registration](#).

8.3. Competitor registrations shall be sent to the Fliegerclub Oschatz e.V. via the responsible national association on the attached **NAC Registration Form**, the **Official Entry Form** and the completed **Organizer Questionnaire**.

Fliegerclub Oschatz e.V.  
Stephanie Koechel  
Wermsdorfer Straße 36  
D-04758 Oschatz  
Tel.: +49 177 78805 06  
E-Mail: [mail@wgac2024.de](mailto:mail@wgac2024.de)  
Website: [www.wgac2024.de](http://www.wgac2024.de)

8.4. Incomplete registrations and registrations with reservations are irrelevant.



8.5. Entries and Registrations only become effective **upon receipt of the entry fee in the organizer's account**. A validation will be sent after full confirmation to the sender.

## 9. Glider Aircraft

- 9.1. It is the sole responsibility of the respective pilot to comply with the aviation regulations and the operating limits according to the respective flight and operating manual. The competition director is authorized to exclude the aircraft or competitor concerned from the championship in the event of obvious disregard of the operating limits (e.g., exceeding the maximum payload).
- 9.2. One glider aircraft can be flown by multiple pilots.
- 9.3. All participating aircraft shall satisfy the performance criteria essential for competition flights in the advanced/unlimited aerobatic category.
- 9.4. For all competing aircraft a valid Certificate of Airworthiness of the related country shall be presented.
- 9.5. For all competing aircraft, liability insurance shall be concluded with respect to damage caused by operation of that aircraft to third parties covering a minimum amount in SDR (Special Drawing Rights) or in equivalent value of any other freely convertible currencies, for the aircraft with MTOW as mentioned below:
  - MTOW up to 500 kg 750.000 SDR (approx. EUR 870.000)
  - MTOW above 500 kg to 1000 kg 1.500.000 SDR (approx. EUR 1.800.000)
- 9.6. Each competing aircraft shall be insured against 3rd Party Public Liability, according to EU Regulation (EC) No. 785/2004, claims with a minimum amount as mentioned above according to MTOW. Aircraft arriving to Germany shall be able to present their insurance policy with a copy in English, certified by the Insurance Company.
- 9.7. All competing aircraft shall be equipped with VHF radio (8.33 kHz).
- 9.8. Each competition glider shall have mounted a unit for placing the altimeter encoder for using the HMD. The HMD mount must be following Section 6 Part 2, Appendix C. Details for HMD device can be found in item 14.
- 9.9. Hangar space for competing aircraft will be available free of charge for the period of the Championship.





9.10. In case of insufficient hangar capacity, priority will be determined by the Organizer. In case of doubt, the order of received Entry Fee payment dates will be taken in account.

9.11. Registered aircraft should be equipped with a wheel dolly for better ground handling and parking in the hangar.

## 10. Free Known (Known) Sequence Submission

10.1. The Free Known (Known) sequence of each competitor should be submitted not earlier than one month (i.e. 1<sup>st</sup> July) and not later than one week before the opening briefing according to FAI Sporting Code, Section 6 Part 2, 2.2.1.9.

10.2. Deadline for the Free Known (Known) submission is on 21<sup>st</sup> July 2024 at 18:00 CEST.

10.3. Competitors may submit their Free Known (Known) sequence to [mail@wgac2024.de](mailto:mail@wgac2024.de). Every submission will be confirmed. Sequence submissions are not valid without confirmation.

10.4. Each competitor shall submit a computer file of his Free Known (Known) sequence in an acceptable format (see CIVA approved Sequence Design System: <https://www.civanews.com/sequence-design-software/>). Acceptable format file is OpenAero.seq file. The computer file shall contain complete pages for forms "A", "B" and "C" as well as forms "L" and "R". The competitor is responsible that the software used has been updated to comply with the Aresti System (Condensed) and Section 6, Part 2 regulations as currently amended by CIVA.

10.5. Hard copies alone or hand drawings will not be accepted.

## 11. Entry Fees

### 11.1. Bank account

The entry fee shall be transferred to the following account **at the same time** as the registration form is sent:

<u>Account holder:</u>	Fliegerclub Oschatz e.V.
<u>Bank:</u>	Volksbank Riesa
<u>IBAN:</u>	DE09 8509 4984 0047 0806 06
<u>BIC:</u>	GENODEF1RIE
<u>Reference:</u>	WGAC <i>or</i> WAGAC 2024 + Name



11.2. The Entry Fees are specified as follows:

- **999,00** EUR per Competitor
- **200,00** EUR per Team Member (not competing)

11.3. The entry fee shall be provided to the Organizer not later than **30<sup>st</sup> April 2024**.

11.4. If payment is made after 30<sup>st</sup> May 2024 and not later than 21<sup>st</sup> June 2024, an additional **250,00** EUR will be charged.

11.5. If payment is made after 21<sup>st</sup> June 2024 or at the contest site, an additional **500,00** EUR will be charged.

11.6. Entry Fees shall be paid in full amount and bank fees shall be charged to sender's account.

11.7. Entry Fees do not include the expenses of any accommodation, meals or aerotows. They rather cover:

- Opening and Closing Ceremony (incl. Dinner)
- CIVA Sanction Fee of 300,00 CHF per Competitor
- HMD Device Usage during competition

11.8. Any competitor wishing to query the arrival and clearance of their fees shall contact the Organizer by contact information provided in item 15 of this document.

## 12. Cancellation Curve & Refund Policy

12.1. If a registered competitor has to withdraw his/her entry, his NAC may substitute another competitor of the same category with no financial penalty. If a competitor wishes to cancel or change its entry, the NAC representative shall contact the Organizer.

12.2. If the competitor cancels his/her participation, the registration fee will be refunded as per the following schedule:

- Withdrawal before 31<sup>st</sup> April 2024 23:59h CEST – 100%
- Withdrawal after 1<sup>st</sup> May 2024 00:00h CEST but before 15<sup>th</sup> May 2024 23:59h CEST – 50%
- Withdrawal after 16<sup>th</sup> May 2024 00:00h CEST – 0%

12.3. Any fees that apply to the Organizer will be deducted before the refund.



12.4. If a competitor is disqualified from the event according to FAI Sporting Code, Section 6 part 2, there will be no refund.

12.5. If the World Championship is cancelled due to "force majeure" e.g. Covid-19 or political crisis, the organizer will retain 25% of the entry fee.

12.6. If the championship is postponed for a certain period due to force majeure, the organizer reserves the right to adjust the above-mentioned fees in consultation with the Host. There is no price fixing.

### 13. Other Fees

13.1. The following fees are to be paid on site to the organizer Fliegerclub Oschatz e.V.:

- Aero-Tow Fees 1250 m AGL: **80,00 EUR<sup>1</sup>** per Take-off
- Aero-Tow Fees 800 m AGL: **65,00 EUR<sup>1</sup>** per Take-off
- Camping fee: **10,00 EUR** per Person and Day
- Camping fee reduced<sup>2</sup>: **5,00 EUR** per Person and Day
- Airfield use fee *for Competitors who do not pay the camping fee but use the airfield*: **5,00 EUR** per Person and Day

13.2. Protest Fee:

- Protest shall be submitted accompanied by the payment of **100,00 EUR**.

### 14. HMD Device

14.1. One system will be available with the measurements below. A second system will be available once testing is completed with positive results.

14.2. The HMD mount will be available free of charge provided by the Organizer for each competing glider. Older mounts can be used after checking for their suitability. HMD box dimensions are approximately the same as in previous years. STL file for self-made 3D printed mount will be provided later.

---

<sup>1</sup> The towing fees were calculated on the basis of fuel prices as at 15.02.2022 (Avgas 100LL 2,20€/l; Super Plus 1,72€/l). The organizer reserves the right to adjust the towing fees in line with the development of fuel costs, which must be announced at the opening briefing at the latest.

<sup>2</sup> Applicable for person younger than 14 years during the competition.

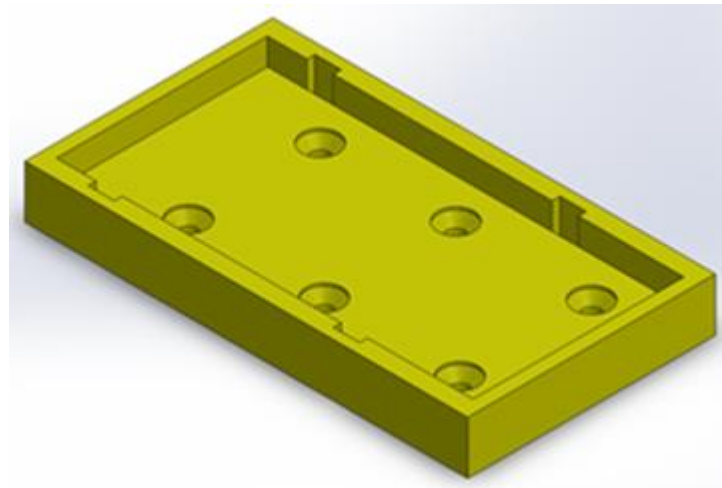
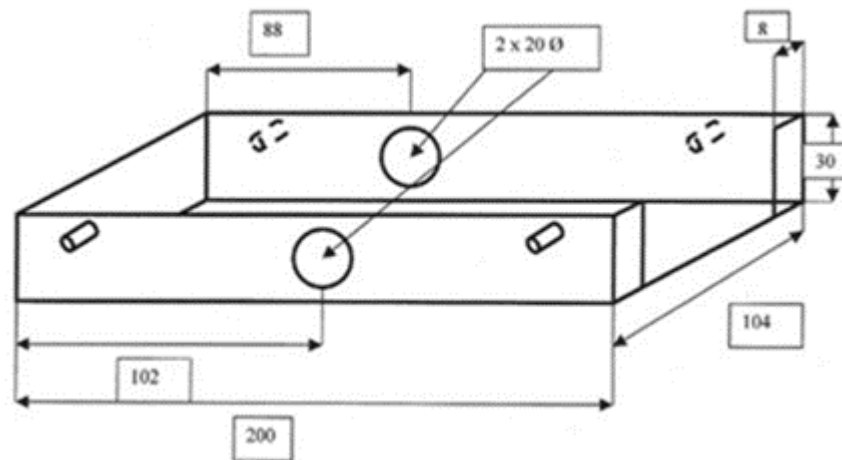

## 15. Written Correspondence

15.1. Inquiries regarding **registration & organization** should be addressed to:

Fliegerclub Oschatz e.V.  
Stephanie Koechel  
Wermisdorfer Straße 36  
D-04758 Oschatz  
Tel.: +49 177 78805 06  
E-Mail: [mail@wgac2024.de](mailto:mail@wgac2024.de)



## 16. Liability, legal action and anti-doping

By submitting the entry form, the participant declares that - except in cases of intent or gross negligence - he/she waives all claims for damages against the organizer and the host as well as their bodies and vicarious agents. This waiver does not apply to the extent that an insurer recognizes and settles a claim.

Furthermore, the participant declares for himself and his team that he recognizes the regulations of the invitation to tender in all points.

If the competitor takes part in the competition with an aircraft owned by a third party, the owner of the aircraft declares that he/she agrees to the limitation of liability for claims arising from damage to his/her aircraft. In the case of minors, the signature of the legal representative is required.

The athlete acknowledges the articles of the WADA and NADA Codes, including the relevant implementing provisions, as well as the anti-doping regulations of Federal Professional Association responsible for him/her, in the version applicable at the time. The athlete hereby undertakes to support the worldwide fight against all forms of performance manipulation, also with regard to the aforementioned institutions and the DOSB. Further valid implementations can be found here <https://www.wada-ama.org/en/what-we-do/world-anti-doping-code>. A list of prohibited substances and methods can be found here <https://www.wada-ama.org/en/news/wada-publishes-2024-prohibited-list>.

Legal recourse is excluded.

## 17. Cancellation of the event

17.1. In cases of force majeure which make it impossible to hold the championship as planned or if the number of participants is too low, the organizer or the host may cancel or postpone the championship without this giving rise to any claims against the organizer or the host.

17.2. If the planned number of programs (6) cannot be flown for technical or meteorological reasons, at least 3 programs shall be completed in the respective class for a valid World Championship (Free Known (Known), 1<sup>st</sup> Unknown, Free Unknown (Free)). If necessary, the competition management will determine which class is to be given priority.



Signed.

---

Contest Director  
*Thomas von Larcher*

---

Representative Aerobatic Gliding DAeC  
*Lars Czernek*

---

Deputy Contest Director  
*Roland Marsch*

Attachments:

- NAC Registration Form\_WGAC\_WAGAC\_2024
- Official Entry Form\_WGAC\_WAGAC\_2024
- Organizer Questionnaire
- Figures Free Known (Known) 2024 "Unlimited" und "Advanced"

## Free Known Figures 2024

### ADV Proposal G

**G K=97**

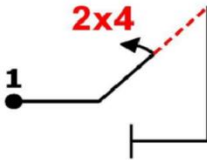
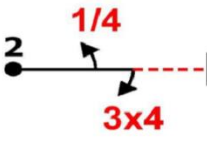
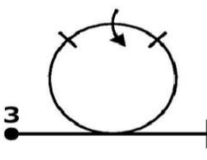
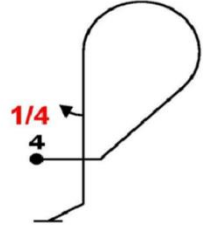
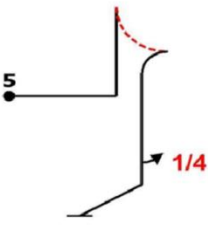
 <p><b>Fig A</b> 1.2.3.1(12) 9.4.2.2(11) <b>K: 23</b></p>	 <p><b>Fig B</b> 1.1.1.3(2) 9.1.3.1(3) 9.4.3.3(12) <b>K: 17</b></p>	 <p><b>Fig C</b> 7.4.1.1(10) 9.1.3.4(12) <b>K: 22</b></p>	 <p><b>Fig D</b> 8.5.9.1(12) 9.1.5.1(3) <b>K: 15</b></p>	 <p><b>Fig E</b> 6.2.2.1(17) 9.1.5.1(3) <b>K: 20</b></p>
--	--	--	--	---

### UNL Proposal G

**G TOTAL K=126**

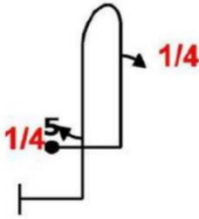
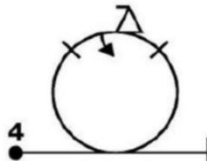
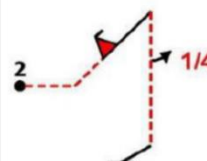
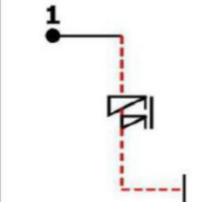
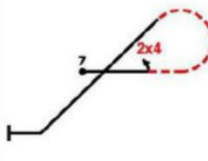
 <p><b>Fig A</b> 8.4.1.1(13) 9.1.1.1(9) 9.1.5.1(3) <b>K: 25</b></p>	 <p><b>Fig B</b> 7.4.1.1(10) 9.9.3.2(12) 9.1.3.2(6) <b>K: 28</b></p>	 <p><b>Fig C</b> 1.2.4.2(14) 9.10.2.2(18) 9.1.5.1(3) <b>K: 35</b></p>	 <p><b>Fig D</b> 1.1.7.3(11) 9.11.1.6(7) <b>K: 18</b></p>	 <p><b>Fig E</b> 8.5.7.1(12) 9.4.3.2(8) <b>K: 20</b></p>
---	--	---	--	--